

FRIGIDAIRE



Top Load Washer

FFTW1001PW

8 Wash Cycles
3.4 Cu. Ft. D.O.E.



Product Dimensions

Height	42-1/2"
Width	27"
Depth	29"

More Easy To Use Features

Ready-Select® Controls

Stainless Steel Drum

Bleach/Fabric Softener Dispenser

Available in:



Classic
White
(W)

Signature Features

Automatic Water Level Adjustment with 4 Manual Options

Delicates Cycle

Wash your clothes without damaging.

Heavy Wash Cycle

This cycle enables you to wash all those clothes with difficult stains.

Fits-More™ Washer

Our new design lets you wash more in one load.

Features	
Washer Type	Top Load
Total Capacity D.O.E. (Cu. Ft.)	3.4
Controls	Ready-Select*
Washer Drum Interior	Stainless Steel
Interior Light	
Vibration Control System	
Framed Glass Window Lid	
Suspension System	Sure-Spin™
Wash System	Agitator
TimeWise® Technology	
Fresh Water Rinse	Yes
WaterFall™ Wash	
Estimated Time Remaining	
Bleach Dispenser	Yes
Fabric Softener Dispenser	Yes
Cycle Status Lights	Yes
Cycle Signal	
Cycle Signal "On/Off"	
Control Lock	
Start/Pause/Cancel Knobs	Yes
Delay Start	
Agitate Speed (Stroke/Min.)	Variable
Spin Speed (Maximum RPM)	850
Sound Package	
Adjustable Leveling Legs	4
Cycles	
Wash Cycles	8
Specialty Cycles	
Options	
Water Temperature Selections	4
Water Levels	Automatic
Spin Speed Selections	
Soil Level Selections	
Energy Saver Option	
Optional Accessories	
Mobile Home Installation Kit	PN# 137067200
Drain Hose Extension Kit	PN# 137098000
Certifications	
ENERGY STAR®	
Specifications	
Power Supply Connection Location	Left Top Rear
Water Inlet Connection Location	Left Rear
Voltage Rating	120V / 60Hz / 15A
Connected Load (kW Rating) @ 120 Volts¹	0.4
Amps @ 120 Volts	8.0
Minimum Circuit Required (Amps)	15
Shipping Weight (Approx.)	118 Lbs.

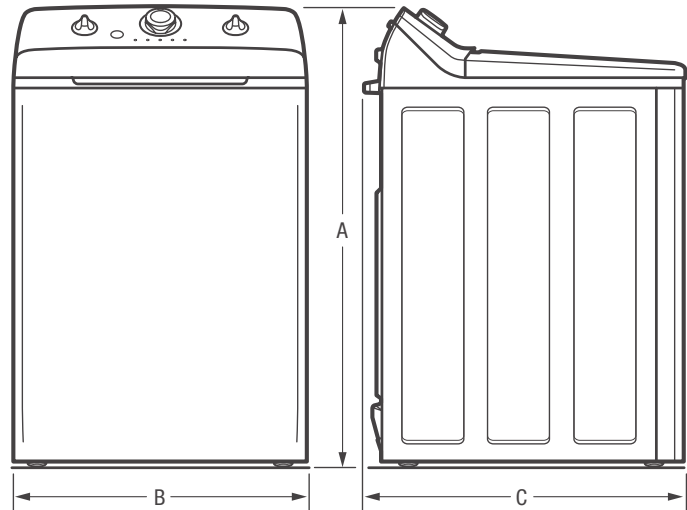

¹For use on adequately wired 120V, dedicated circuit having 2-wire service with a separate ground wire. Appliance must be grounded for safe operation.

NOTE: For planning purposes only. Always consult local and national electric and plumbing codes. Refer to Product Installation Guide for detailed installation instructions on the web at frigidaire.com.



Product Dimensions	
A - Height	42-1/2"
B - Width	27"
C - Depth	29"

Accessories information available on the web at frigidaire.com

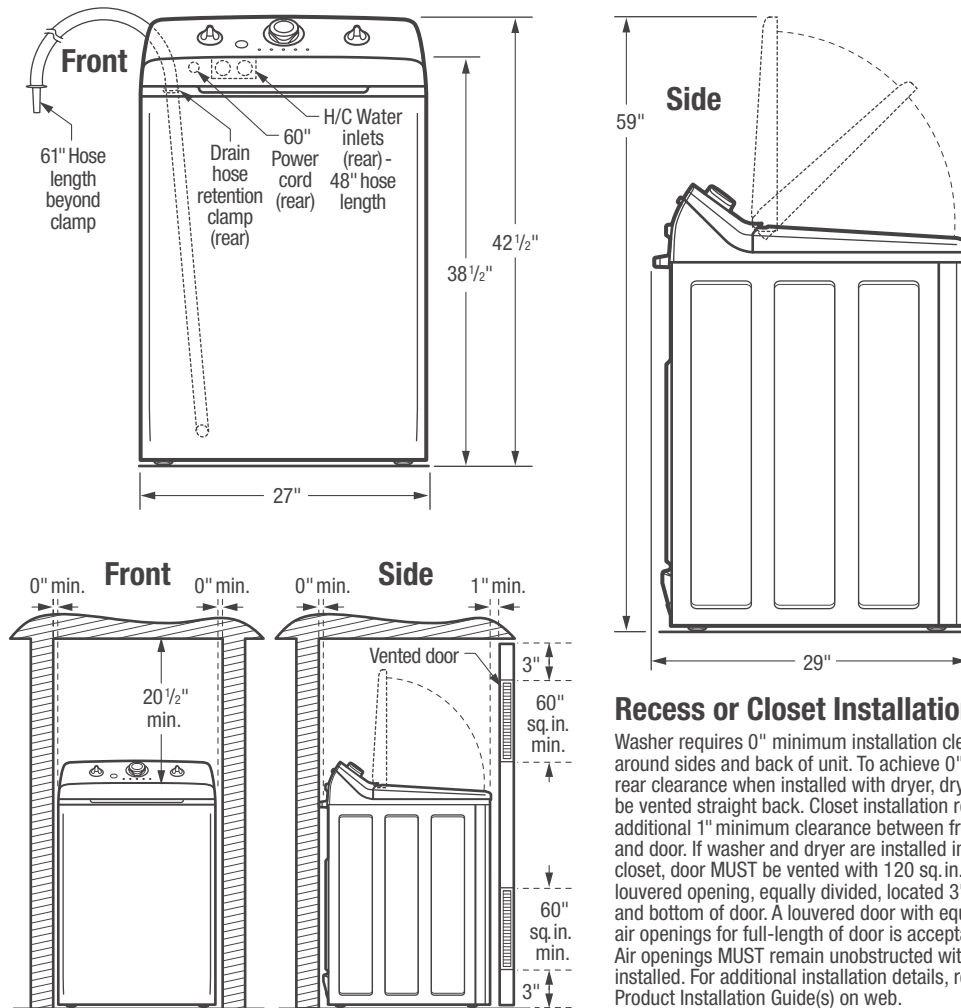

Recess or Closet Installation

Washer requires 0" minimum installation clearance around sides and back of unit. To achieve 0" minimum rear clearance when installed with dryer, dryer **MUST** be vented straight back. Closet installation requires additional 1" minimum clearance between front of unit and door. If washer and dryer are installed in same closet, door **MUST** be vented with 120 sq. in. minimum louvered opening, equally divided, located 3" from top and bottom of door. A louvered door with equivalent air openings for full-length of door is acceptable. Air openings **MUST** remain unobstructed with door installed. For additional installation details, refer to Product Installation Guide(s) on web.

Top Load Washer Specifications

- Product Shipping Weight (approx.) - 118 Lbs.
- An electrical supply with grounded three-prong receptacle is required. The power supply circuit must be installed in accordance with current edition of National Electrical Code (ANSI/NFPA 70) and local codes & ordinances. *(Do not use same circuit as dryer.)*
- Voltage Rating - 120V/60 Hz/15 Amps
- Amps @ 120 Volts = 8.0 Amps
- Equipped with 120V 3-wire power supply cord, approx. 60" long.
- Always consult local and national electric & plumbing codes.
- To maximize detergent effectiveness, ambient temperature should never be below 60° F.
- Washer can be installed in recess or closet requiring 0" minimum installation clearance around sides and back of unit. To achieve 0" minimum rear clearance when installed with dryer, dryer **MUST** be vented straight back. Closet installation requires additional 1" minimum clearance between front of unit and door. If washer and dryer are installed in same closet, door **MUST** be vented with 120 sq. in. minimum louvered opening, equally divided, located 3" from top and bottom of door. A louvered door with equivalent air openings for full-length of door is acceptable. Air openings **MUST** remain unobstructed with door installed. *(For additional installation details, refer to Product Installation Guide on web.)*
- Do NOT install in area exposed to dripping water or outdoor weather conditions; or where gasoline or other flammables, including automobiles, are kept or stored.
- Floor **MUST** be solid with 1" maximum slope. To minimize vibration or movement, reinforcement of floor may be necessary. Do NOT install on carpeted surface.
- Leveling legs supplied to level unit properly and reduce excessive noise and vibration.
- H/C water faucets **MUST** be installed within 42" of washer's water inlet and **MUST** be 3/4" with threading for laundry hose connection to connect to 48" inlet hoses.
- Water pressure **MUST** be between 30 and 120 psi with NOT more than 10 psi pressure difference between hot and cold.
- Drain standpipe requires diameter of 1-1/4" min. and height of 36" min./96" max. above floor, capable of eliminating 17 gallons per minute. Attached 61" drain hose can reach 74"-high standpipe. For higher standpipe, optional Drain Hose Extension Kit available.
- For manufactured or mobile home installation optional Mobile Home Installation Kit (PN# 137067200) required. *(For specific installation details, refer to Product Installation Guide on web.)*

Note: For planning purposes only. Refer to Product Installation Guide on the web at frigidaire.com for detailed instructions.

Optional Accessories

- Mobile Home Installation Kit - (PN# 137067200).
- Drain Hose Extension Kit - (PN# 137098000).

FRIGIDAIRE

USA • 10200 David Taylor Drive • Charlotte, NC 28262 • 1-800-FRIGIDAIRE • frigidaire.com
 CANADA • 5855 Terry Fox Way • Mississauga, ON L5V 3E4 • 1-800-265-8352 • frigidaire.ca

